



AVK FIXED SURFACE BOX

04/10

Cast iron, with distance rings

001



AVK offers a very wide range of surface boxes in fixed, floating and height adjustable designs. The surface boxes of cast iron are pre-mounted with a sealing for optimum tightness between lid and body. The large chamber provides easy access for mounting and demounting extension spindles and the closed design protects the extension spindle against sand and dirt.

Product Description:

Fixed surface box - distance ring and square of ductile iron

Standards:

- Designed to all standards

Features:

- Body and lid of grey cast iron
- Distance rings of ductile iron in 10-50 mm height
- Lid sealing of NBR rubber
- Epoxy coating to DIN 30677
- Lid inscriptions: "Vand - AVK", "Water - AVK" or "Gas - AVK"

Accessories:

Support tile, type 1



AVK FIXED SURFACE BOX

Cast iron, with distance rings

04/10

001

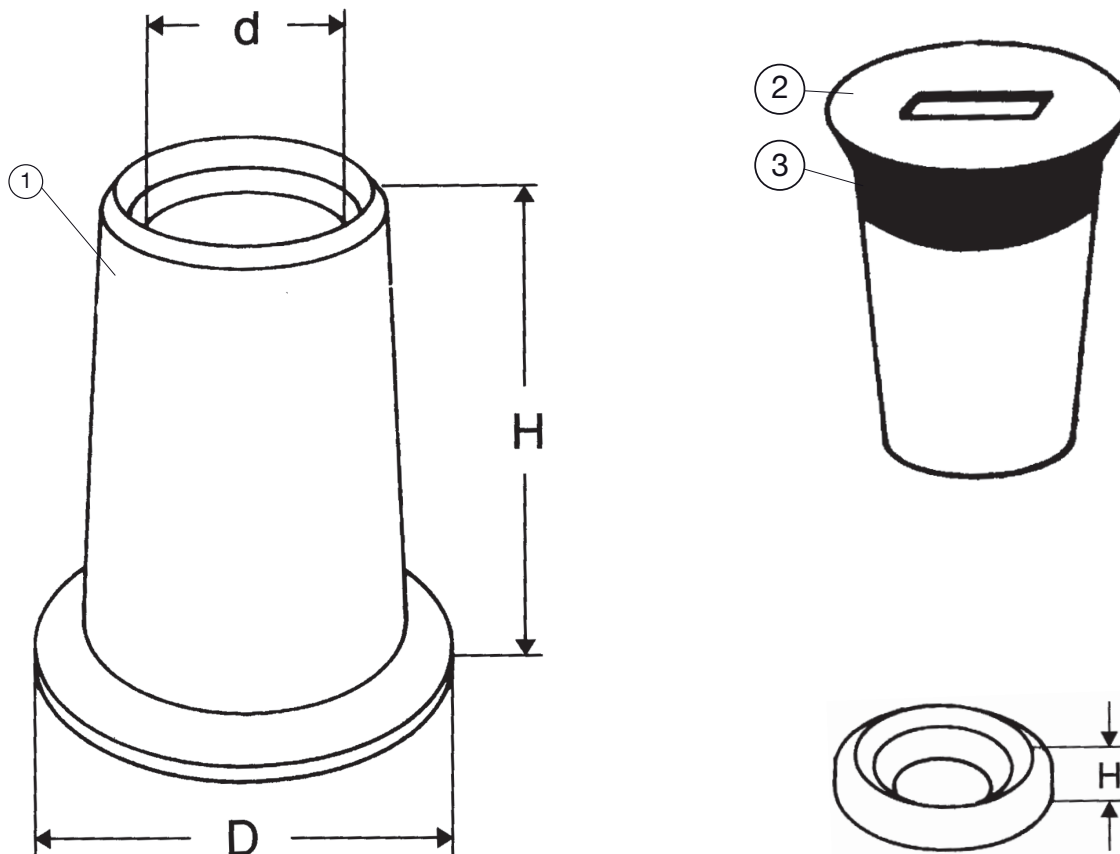

Component List:

1. Body	Grey iron GJL-250 (GG-25)	2. Lid	Grey iron, GJL-250 (GG-25)
3. Lid sealing	NBR rubber		

Components may be substituted with equivalent or higher class materials without prior notification.

Reference Nos. and Dimensions:

AVK ref. nos	H mm	D mm	Dd mm	Theoretic. weight kg
04-00051-00052-00 ⁽¹⁾	190	195	83	6.3
04-00051-00066-00 ⁽²⁾	190	195	83	6.3
04-00051-00069-00 ⁽³⁾	190	195	83	6.3
04-000-52-00 ⁽⁴⁾	-	-	-	1.8
04-000-66-00 ⁽²⁾	-	-	-	1.8
04-001-53-00 ⁽⁵⁾	10	-	83	1.0
04-001-54-00 ⁽⁵⁾	20	-	83	0.8
04-001-55-00 ⁽⁵⁾	30	-	83	1.1
04-001-56-00 ⁽⁵⁾	40	-	83	1.4
04-001-57-00 ⁽⁵⁾	50	-	83	1.9

⁽¹⁾ Complete surface box, lid inscription "VAND" (without distance ring)
⁽²⁾ Lid inscription "GAS - AVK"
⁽³⁾ Lid inscription "Water - AVK"
⁽⁴⁾ Lid inscription "VAND - AVK"
⁽⁵⁾ Distance ring